

CHICAGO FAUCETS®

+ Healthcare

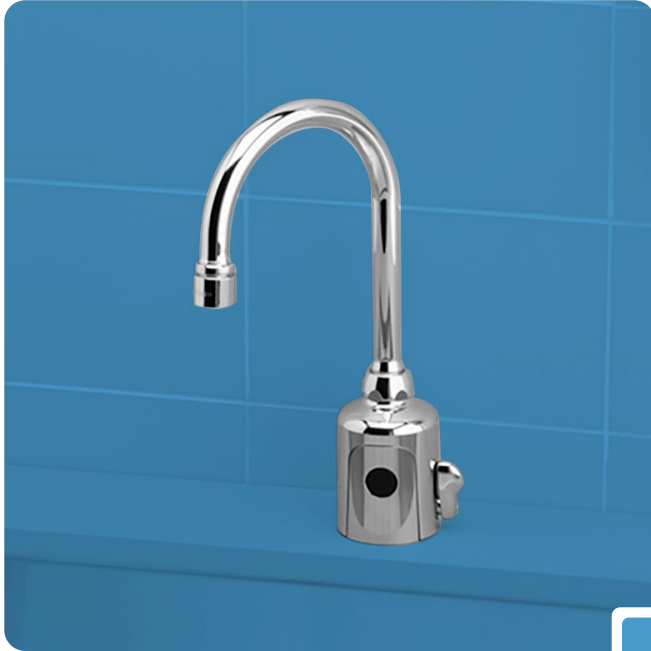

Engineered for **Patient Safety**

Proven Plumbing Solutions for Every Area of Your Facility

Designed With Care, **For Care**

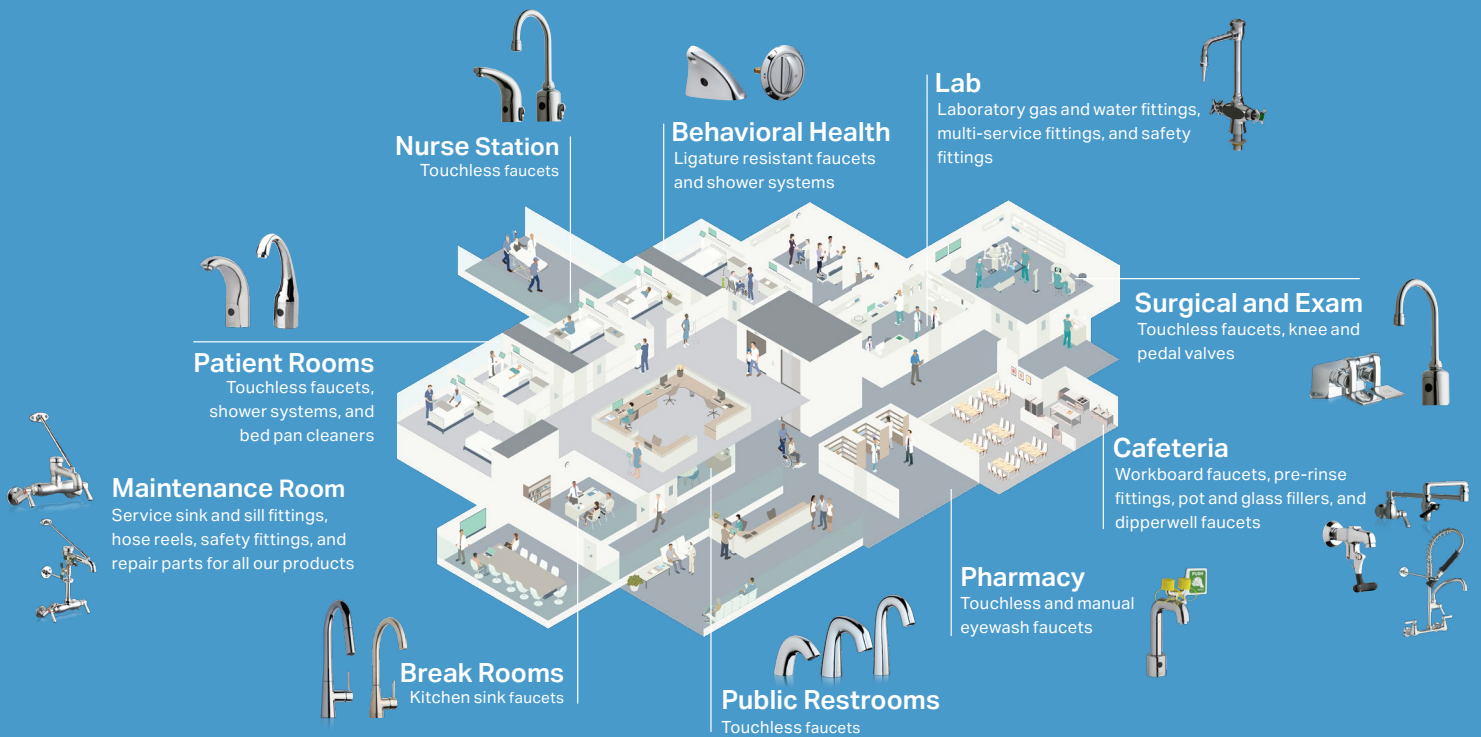

Elevating Patient Care Through Innovative Engineering

At **Chicago Faucets**, we understand that in healthcare facilities every detail matters. That's why we've dedicated ourselves to developing faucets and showers that not only meet but exceed the rigorous standards set by ASHRAE, ANSI, the Joint Commission, and the CDC for infection prevention.

As new and emerging water management standards reshape the healthcare landscape, it is crucial that healthcare facilities specify and install plumbing equipment that meets and exceeds those standards. Every department, from surgical units to patient rooms, relies on properly managed water systems to maintain safe conditions and protect the immunocompromised.

Chicago Faucets is committed to supporting your mission by manufacturing faucets and fittings that help you minimize infections. Our products are designed to ensure that your facility meets the most stringent industry codes and standards, helping deliver better care quality and safer environments for all patients.



Table of Contents

Chicago Faucets offers a comprehensive selection of faucets and showers specifically designed for healthcare settings, helping to reduce waterborne bacteria and support the fight against healthcare-acquired infections.

Page 2	Infection Prevention – <i>HyTronic® Faucets</i>
Page 6	Stagnation Prevention – <i>Auto-Drain® Shower System</i>
Page 12	Scald Protection – <i>Thermostatic Mixing Valves, Faucets, Showers</i>
Page 16	Manual Faucets
Page 18	Foot Pedals and Knee Valves
Page 20	Behavioral Health – <i>Ligature Resistant Faucets and Showers</i>
Page 22	Safety and Laboratory Fittings
Page 27	Food Service – <i>Fittings for Kitchens</i>
Page 28	Maintenance – <i>Manual Faucets</i>

Infection Prevention

HyTronic® Patient Care Series

HyTronic® Patient Care Touchless Faucets: for High Risk Patient Care Areas



Traditional Faucets

Durable solid brass construction

- + Advanced hygiene flush options available through the CF Connect app
- + Improved ease of use with a higher spout profile
- + Meet spec requirements with user temperature control and emergency back-up power supply



Gooseneck Faucets

Version meets the 6" wide reach for FGI Guidelines

- + Advanced hygiene flush options available through the CF Connect app
- + Improved accessibility with gooseneck spout
- + Versatile design with your choice of plain end or laminar outlet
- + Flexible and easy installation with components located above the deck



Also available with User-adjustable Temperature Control



Engineered for Patient Safety

Antimicrobial Laminar Outlet

Provides additional integrated protection, reducing the potential for growth of bacteria, mold, and mildew.

Patient-Specific Operating Modes

Easily programmed for water saver, hand wash, volume, and cleaning modes.

CF Connect App

Provides a secure and easy way to adjust and maintain the faucet with a smartphone.

- Hygiene Flush eliminates stagnant water from the plumbing system
- Six field-adjustable modes for metering, water savings, and detection ranges
- Track Usage



Durable Construction

High-quality cast brass with a refined finish for unrivaled durability.



Low-volume solenoid valve helps to minimize stagnant water in the faucet.

Integral Checks

Prevents water from flowing back from the mixing valve and contaminating the rest of the system.



Copper Supply Lines

Inhibit the growth of various bacteria and pathogens, including Legionella, Staphylococcus aureus, and Escherichia coli.

Tested and Enhanced for the Most Critical Spaces

Improve patient safety and avoid constant maintenance

- + **Integrated Protection:** Our laminar flow outlet and copper piping ensure a safer and cleaner faucet.
- + **Easy Management:** The CF Connect app is a convenient way to adjust settings and track usage.
- + **Lower Maintenance:** Our superior sensor offers reliable use through millions of activations.
- + **Versatile Spec Options:** Point-of-use scald protection and special operating modes provide additional safeguards to help keep everyone in the building safe. HyTronic® for Patient Care is available as a faucet only or in a complete kit with a mixing valve and supply stops.
- + **Long-Term Peace of Mind:** Our range of power options provides you the confidence that your faucet will be in operation as long as you need it.



Tested for Performance: Through rigorous testing conducted by the University of Pittsburgh under the guidance of the Special Pathogens Laboratory, we have achieved microbial contamination levels statistically similar to those of conventional manual faucets.



Infection Prevention

HyTronic® Series Touchless Faucets

HyTronic® Series sets the standard for infection mitigation, reliability, and user comfort. Backed by continuous laboratory testing, HyTronic® faucets boast an impressive track record with millions of flawless activations. Coupled with the renowned durability of Chicago Faucets, HyTronic® sets the standard for touchless faucets, delivering unparalleled performance for your investment.

HyTronic® Faucets Feature:

- + **Integrated Protection:** An antimicrobial flow outlet is available on select models. It delivers extra integrated protection to help reduce the growth of bacteria, mold, and mildew.
- + **Scald Prevention Options:** Install a thermostatic mixing valve below deck for safe, consistent temperature with hot water pipe flush mode. For an integrated ASSE 1070 certified thermostatic mixer built into the faucet to minimize leak points, specify HyTronic® TempShield®.
- + **Flexible Power Options for Peace of Mind:** Choose our Long Term Power Supply, Emergency Back-Up Power System, or Self Sustaining Power Supply that uses the flow of water to create and store power.
- + **Superior Sensor Technology:** HyTronic® boasts one of the best touchless sensors in the industry, trusted by healthcare professionals for nearly two decades. The dual beam infrared sensor operates reliably through millions of activations.

Easily Maintain Faucets with the CF Connect App:

- + **Customization:** Use the CF Connect app to adjust your faucet based on your facility's needs with six user settings and three flushing protocols.
- + **Operating Modes:** Normal Mode, Scrub Mode, Metering Mode, Water Saver Mode, Handwash Mode, and Volume Mode.
- + **Hygiene Flush Settings:** Schedule use-based, interval-based, or volume-based hygiene flush mode to reduce water stagnation and keep water lines clear and fresh.



Retrofit Kits Available: Upgrade your existing HyTronic® faucet with Bluetooth® communication and use the CF Connect app for water management.

Proven for **Healthcare Facilities**

The HyTronic® Series set the standard for reliability, safety, and user comfort in both healthcare and commercial buildings.



Traditional HyTronic® Series

Durable solid brass construction

- + Engineered and manufactured in the United States using durable solid brass
- + Includes a perfect reach for patient or staff handwashing
- + Available with multiple flow options to meet sustainability requirements



Gooseneck HyTronic® Series

Combines high clearance and deep reach

- + Accessible design with gooseneck spout and choice of plain end or laminar outlet
- + Hygiene flush mode factory set to eliminate stagnant water from the plumbing system
- + Comes in both Deck and Wall Mount
- + Models available that comply with the Facility Guidelines Institute rule of 6" reach for hospital design



Contemporary Spout HyTronic® Series

Hands free hygienic faucet with open arc spout

- + Popular model with a high C-Curve
- + Quick response with dual-beam design, automatically adjusts to environmental changes



Curve Spout HyTronic® Series

- + Automatic faucet with mid-arc spout that melds to curved body
- + Quick response with dual-beam design, automatically adjusts to environmental changes



Available with Integrated Thermostatic Mixing Valve



Stagnation Prevention

Introducing the **Auto-Drain® Shower System**

The First Hospital Shower System That **Removes Water Automatically**

Now, hospitals and plumbing engineers can specify and install an Auto-Drain® Shower System with the flexibility in design to provide quality care, reduce waterborne infections, and meet water sustainability requirements.

Auto-Drain® helps safeguard the health and well-being of occupants by removing stagnant water in shower areas.



Stagnant water in showers can create a rich environment for the growth of Legionella and other waterborne pathogens. In a private study, research showed that 74% of facility managers were concerned about stagnant water in the pipes and 64% were concerned about stagnant water in the hoses.

When water is shut off, the Auto-Drain® valve automatically drains the water from the pipes and hose in less than a minute. Auto-Drain® assemblies in the shower hose and shower valve drain water after each use. This simplifies the draining process and limits the growth of waterborne pathogens.

The Only System that Removes Stagnant Water

AUTO-DRAIN[®] SHOWER SYSTEM

special hose valve purges
residual water

Engineered for **Stagnation Prevention**

The Chicago Faucets Auto-Drain[®] Shower System is the only system that purges dangerous standing water in the valve, pipes, and hoses of the shower system while meeting the wide variety of specification requirements in commercial applications, especially in healthcare applications.

Drains integrated into the valve and hand spray hose remove water from the system after each use. It is easy to install the Auto-Drain[®] valve, trim, and integrated or remote drain. There's no need to choose between a fixed shower head or hand spray in the patient shower. The Auto-Drain[®] diverter valve allows both the shower column and hand spray hose to drain completely at shutoff, regardless of the position of the diverter handle.

- + **Adaptable:** Design flexibility incorporates the choices of Thermostatic/Pressure Balancing or Pressure Balancing valves (with integral or remote drain), dual spray showers with diverter, low flow sustainable valves, and simple hose retrofit assemblies with Auto-Drain[®].
- + **Easy to use:** An optional hand-held shower spray includes a built-in Auto-Drain[®] valve that drains the hand spray hose automatically after each use. This simplifies the draining process: shower hoses do not need to be draped or dropped to the ground to drain. Retrofit hose assemblies offer an ideal way to add Auto-Drain[®] to an existing shower installation.

Stagnation Prevention

Auto-Drain® Shower System

The Auto-Drain® Thermostatic/Pressure Balance Shower System is designed to help reduce the growth of pathogens by removing stagnant water in the shower valve, pipes, and hoses. Drains integrated into the valve and hand spray hose automatically flush water out of the system after each use.



- + **Automatic Valve Drain:** When the shower is shut off, water drains automatically from the valve in less than a minute.
- + **Auto-Drain® Diverter:** For dual spray showers, the Auto-Drain® Diverter Valve drains the water from the pipes regardless of the position of the diverter handle. It is ideal for facilities with a shower head and hand spray.
- + **Thermostatic/ Pressure Balancing Valve:** Provides extra protection from scalding and thermal shocks by constantly monitoring both the water temperature and pressure.
- + **Durable Construction:** Cast brass valve body is designed for back-to-back installations.
- + **Extra Safety and Convenience:** Brass limiter helps reduce maximum hot water temperature. Integral check stops for easy maintenance.

Auto-Drain[®] Thermostatic/Pressure Balance Valve



1921 Series Thermostatic/Pressure Balance Valve, Round Trim
With Integral Auto-Drain[®]

- + Auto-Drain[®] drains water out of system after each use
- + Reduces stagnant water in the shower system piping
- + Protects against changes in both pressure and temperature
- + Available with Auto-Drain[®] Diverter



1920 Series Thermostatic/Pressure Balance Valve, Round Trim
With Remote Auto-Drain[®]

- + Auto-Drain[®] drains water out of system after each use
- + Protects against changes in both pressure and temperature
- + Traditional round trim in polished chrome finish
- + Available with Auto-Drain[®] Diverter



1920 Series Thermostatic/Pressure Balance Valve, Square Trim
With Remote Auto-Drain[®]

- + Auto-Drain[®] drains water out of system after each use
- + Protects against changes in both pressure and temperature
- + Contemporary square trim in polished chrome finish
- + Available with Auto-Drain[®] Diverter



System includes a choice of three trim designs, an integrated or separate drain valve, and the option for an Auto-Drain[®] Diverter Valve.



Stagnation Prevention

Auto-Drain® Pressure Balance Valve

Many healthcare facilities have master thermostatic water mixing valves. A pressure balancing valve is designed to respond immediately to changes in hot or cold water pressure to provide a safe, comfortable shower. If either supply pressure fails, the valve will shut down instantaneously.



1911 Series Pressure Balance Valve

With **Integral Auto-Drain®**

- + Senses hot to cold water volume ratio and adjusts to maintain consistent pressure
- + Responds immediately to changes in hot or cold water pressure for maximized comfort
- + If either supply pressure fails, valve shuts down immediately
- + Available with Auto-Drain® Diverter



1910 Series Pressure Balance Valve

With **Remote Auto-Drain®**

- + Remote drain automatically drains water from the spray and hose after each use
- + Mounting options include a selection of ADA grab bars or stylish slide bars
- + Water savings with a choice of 2.5 GPM, 1.75 GPM, or 1.5 GPM hand sprays with pause control
- + Available with Auto-Drain® Diverter



Shower Heads and Slide Bars

All Auto-Drain® Systems are available with choice of shower head or hand shower

- + Choice of four shower heads or hand spray with Auto-Drain®
- + Also available with 24" and 48" slide bars

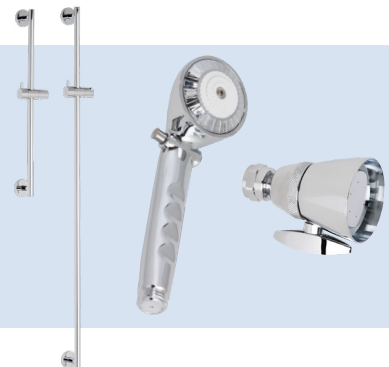

Award-Winning Shower System



The Auto-Drain® Shower System automatically drains standing water from the valve, diverter, pipe, and hand spray hose. Drains integrated into the valve and hand spray hose remove water from the system after each use. Purging residual water helps to prevent the growth of harmful waterborne pathogens. Stagnant water in shower systems poses a significant risk for the spread of bacteria.

Scald Prevention



Products Designed to Deliver **Comprehensive Scald Prevention**

Available exclusively from Chicago Faucets, TempShield® anti-scald products provide efficient installation and fewer potential leak points. Rigorously tested to meet the latest codes for lavatory and shower projects, they make it easy to stay in compliance at your facility.

ASSE 1070 Certified Thermostatic Mixing Valve for Tempered Water - Designed for easy installation with electronic and manual faucets, the 131 Series Mixing Valve makes any faucet ASSE 1070 compliant. Valves with integrated thermal flush allow hot water disinfection without bypassing piping.

- + **Tamper Resistant:** Prevent unauthorized personnel from putting the valve into thermal disinfection mode.
- + **Easy Installation:** With 3/8" compression connections for standard lines.
- + **Flow Rate:** A 4.6 GPM flow rate delivers tempered water to multiple faucets with one 131 Series valve.
- + **Easy Maintenance and Reliable Operation:** One-piece replaceable cartridge with an integrated screen filter. Dual check valves for cross-flow protection.
- + **Quality:** Heavy-duty, cast brass valve body is backed by a lifetime limited warranty.

ASSE 1070 for Faucets - For devices intended to limit hot or tempered water temperature supplied to lavatories:

- + Valves must be thermostatic and provide scald protection at the rated flow rate of the fixture. The device must limit the water temperature to 120°F or lower.
- + Faucets can have an integrated thermostatic design or an add-on valve.
- + Highest outlet temperature for non-adjustable temperature fixtures must be 120°F.

ASSE 1016 for Tubs/ Showers - For tub and shower fixtures that are adjusted and controlled by the user:

- + Valves can be pressure-balancing, thermostatic, or combination.
- + In-line thermostatic valves may not be utilized to meet this standard.

ASSE 1070 /1016 Certified Integrated Scald Protection

- + Valves must provide scald and thermal shock protection for the rated flow rate of the fixture and must be set to a maximum output temperature of 120°F prior to occupancy.
- + Check and adjust the limit stop seasonally for cold water temperature changes.

ASSE 1070 Certified Faucets



E-Tronic® Series Touchless Lavatory Faucet

- + Optional integrated ASSE 1070-certified thermostatic protection cuts installation time by 80%
- + Dependable operation with field-adjustable modes and detection ranges for optimum performance
- + Matching soap dispenser available in polished chrome or matte black finish



ELR Series Touchless Lavatory Faucet

- + Optional integrated ASSE 1070-certified thermostatic protection to help prevent scalding
- + Durable with heavy-duty brass body and vandal resistant outlet
- + Secure, compact control box conceals power, solenoid, mixing valve, and supply



EQ® Series Touchless Lavatory Faucet

- + Optional integrated ASSE 1070-certified thermostatic protection eliminates as many as six leak points
- + Heavy duty one-piece brass spout and waterproof electronics for unsurpassed reliability
- + Smart outlet integrates electronics module, sensing eye, and outlet for a clean look and dependable operation
- + Power options include sustainable water turbine or long term battery



410-T and 420-T Series Single Control Manual Lavatory Faucet

- + Integrated ASSE 1070-certified protection built right into the cartridge
- + Reliable high quality ceramic discs are tested up to 500,000 cycles
- + Fast and easy installation cuts install time in half



Sustainable and low flow options available. Choice of Long Term Power Supply (15+ year battery), Self-Sustaining Power Supply (water turbine), AC, and DC power options. More information available at chicagofaucets.com/power-options-for-faucets.

Scald Prevention



Thermostatic/Pressure Balancing Precision Valve

Our ASSE 1016 Certified Shower Valves provide extra patient safety with protection against pressure and temperature change, smooth operation, and proven durability.

The TempShield® thermostatic/pressure balancing valve allows precise temperature selection and provides near instantaneous response to changes in both hot and cold line pressure and temperature.

Choice of Cartridge

Select Quatern™ or ceramic disc cartridge.

Added Safety

Protects against both temperature and pressure changes.

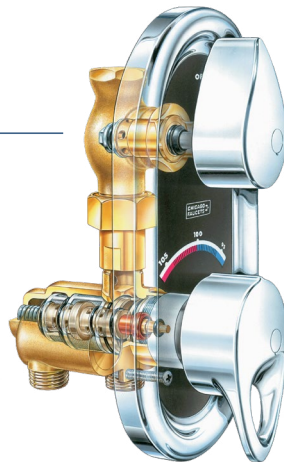

Easy Installation

1/2" NPT female inlets and outlets.

User Convenience

Allows user to select specific temperature for the entire shower.



2500 Series Thermostatic/Pressure Balancing Shower Valve

- + Precision temperature selection
- + Maintains steady temperature regardless of fluctuations in incoming pressure or temperature
- + Tested and factory preset not to exceed 112° F to safeguard against scalding



ADA Compliant **Grab Bars**

Complete your shower system for additional patient safety

- + Designed for systems with integrated locking hand spray holder
- + Durable stainless-steel construction with polished chrome finish
- + Versatile grab bars in 24" ADA and 36" ADA lengths with models including shower and hose

ASSE 1016 Certified Shower Valves



1920 Series Thermostatic/Pressure Balancing Shower Valves

- + Extra safety with protection against changes in both pressure and temperature
- + Advanced thermal actuator technology, maintains a consistent temperature
- + Versatile design with a choice of round or square trim and three handle styles



1910 Series Pressure Balancing Shower Valves

- + Immediate response to changes in hot or cold water pressure to maintain safe temperature
- + Proven and dependable ceramic cartridge for smooth operation
- + Rugged brass valve body provides unsurpassed durability

Shower Options



773, 774, and 763 Series Shower Diverter Valve

- + 3-position brass valve with one inlet and 3 independent outlets
- + Indexed slip flange for ease of use



150 Series Hand Spray Assembly

- + Choice of 1.5 GPM, 1.75 GPM, or 2.5 GPM hand spray with pause control
- + Prevents back flow with in-line atmospheric vacuum breaker
- + Durable 59" hose in stainless steel or vinyl; Auto-Drain[®] hose is also an option
- + Available with various lengths of grab/slide bars

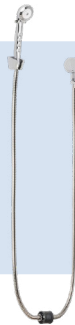

Manual Faucets

Ergonomic Manual Faucets

Manual Faucets **for Patient Safety**

Manual faucets continue to play a crucial role in hospital settings, particularly in surgical areas for scrubbing. Chicago Faucets focuses on ergonomic designs with wrist blade or lever handles and gooseneck spouts that meet the FGI guidelines for 6" extended reach. Facility managers select the Chicago Faucets brand for its durability, ease of maintenance, and parts availability. Chicago Faucets also offers manual faucets with non-aerating or vandal-proof outlets and the option to operate via knee or foot pedals.

Manual faucets, especially gooseneck models, are widely used in hospitals for several compelling reasons:

- + **Reliability and Control:** In critical areas like operating rooms, manual faucets provide surgeons and medical staff with precise control over water flow and temperature. This level of control is essential during surgical scrubbing procedures, where consistent and adjustable water flow is crucial for thorough hand hygiene.
- + **Reduced Risk of Contamination:** While touchless faucets have gained popularity, manual faucets with elbow-operated handles are still preferred in some surgical areas. These designs allow medical professionals to operate the faucet without using their hands, reducing the risk of recontamination after scrubbing.
- + **Durability and Maintenance:** Manual faucets are known for their robustness and longevity. They typically require less maintenance compared to electronic models, which is particularly important in high-stress hospital environments where equipment reliability is paramount.
- + **Cost-Effectiveness:** For hospitals operating on tight budgets, manual faucets often present a cost-effective solution. They have lower initial costs and reduced long-term maintenance expenses compared to their electronic counterparts.



The latest **Facility Guidelines Institute (FGI)** requirements now mandate 6-inch wide-reach gooseneck faucets for handwashing stations in specific healthcare settings. This ensures adequate space for proper hand hygiene while reducing the risk of contact with sink surfaces. When specifying new faucets, it's essential to choose models that meet these updated standards to support infection prevention and compliance.



Engineered to Deliver **High Performance**

Selecting Manual Faucets **for Healthcare**

When selecting faucets for hospital use, it's crucial to consider factors such as durability, ease of cleaning, infection control features, and compliance with healthcare regulations.

In addition to a full line of manual faucets for every space of a facility, the 434 and 436 Series of High Arc manual faucets are ideal for break rooms and kitchenettes. Chicago Faucets offers the 895 and 786 Series of manual gooseneck faucets for healthcare applications.



895 Series Gooseneck Manual Faucets

Known for their robust design, these faucets feature a sleek gooseneck spout that provides ample clearance for various tasks.



786 Series Gooseneck Manual Faucets

This series offers a classic design with modern functionality. The 786 series is engineered for durability and ease of maintenance, featuring interchangeable parts that simplify repairs and replacements.



434 and 436 Series High Arc Manual Faucets

The High Arc line of kitchen faucets delivers commercial durability with easy drop-in installation. They are a great new option for high-traffic commercial applications like physician offices, breakrooms, and hospital cafeterias. The 434 Series includes pull-down spray. Both series are available in matte black, polished chrome, and brushed nickel.



Certain models in this series meet the **Facility Guidelines Institute (FGI)** wide reach guidelines, making them ideal for healthcare and food service settings where accessibility and ease of use are paramount.

Foot Pedals and Knee Valves

Hands-Free Faucet Activation

Foot Pedals and Knee Valves

Foot pedals and knee valves are commonly used for operating manual faucets in hospitals for Infection Control. These devices allow medical professionals to operate faucets without using their hands, which is crucial for maintaining hygiene in healthcare settings. By eliminating the need to touch faucet handles, any healthcare facility can significantly reduce the risk of cross-contamination between patients and staff.

Key Benefits:

- + **Hands-Free Operation:** Medical staff can control water flow without using their hands, which is especially important after scrubbing for surgery or when hands are contaminated.
- + **Improved Hygiene:** By reducing touch points, these valves help maintain a cleaner environment and support infection prevention protocols.
- + **Versatility:** Foot pedals and knee valves can be installed on various faucet types, making them adaptable to different hospital areas.
- + **Water Conservation:** Some models feature self-closing mechanisms, which can help conserve water by automatically shutting off the flow after use.



Foot pedals provide control without touch in operating rooms, scrub stations, patient care areas, laboratories, and food preparation areas.

Control Faucet by **Foot or Knee**

By incorporating foot pedals and knee valves, hospitals can significantly enhance their infection control measures and provide a more hygienic environment for both patients and staff. For control of dispensing cold and hot water for use with:

- + **Gooseneck faucets:** Common in surgical scrub areas and other clinical settings
- + **Wall-Mounted Faucets:** Often found in patient care areas and utility rooms
- + **Deck-Mounted Faucets:** Used in various hospital locations where a sink is present



Long Foot-Operated Remote Pedals

- + Locking feature to keep pedals in a raised position, supply stops include loose key
- + Naiad metering cartridge with adjustable cycle time closure
- + Select from single or double pedal valves

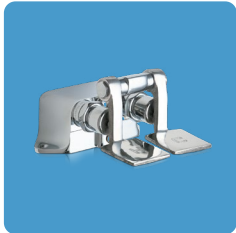

Short Foot-Operated Remote Pedals

- + Select from single or double pedal valves
- + Naiad metering cartridge with adjustable cycle time closure

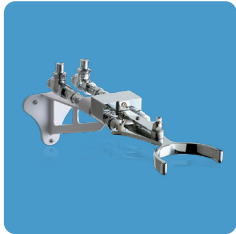

Knee-Operated Remote Valves

- + Cam type knee valve cartridge with fast cycle time closure
- + Slow compression operating cartridge is serviceable for maximum reliability



Bed Pan Cleaners

- + Available with remote pedal valve
- + Includes 48" white vinyl hose assembly
- + More styles available

Ligature Resistant

ELR Series Ligature Resistant* Touch Free Faucet

ELR Series Ligature Resistant* Touch Free Faucet

The added safety of ligature resistance and touchless operation combined with the durability of a one-piece, cast brass body

Ligature Resistant

Rounded and sloped design to minimize ligature points.

CF Connect App

Provides a secure and easy way to adjust and maintain the faucet with a smartphone.

- Hygiene Flush eliminates stagnant water from the plumbing system
- Six field-adjustable modes for metering, water savings, and detection ranges
- Track Usage

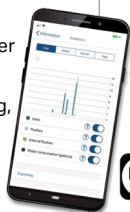

Durable Construction

Heavy-duty, one-piece cast brass body with recessed vandal-resistant outlet to withstand abuse and tampering.

Added Safety

Available with integral ASSE 1070 certified thermostatic protection to help prevent scalding.

Secure, Compact Control Box

Conceals and secures power, solenoid, mixing valve, and supply.

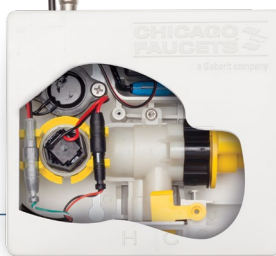

Behavioral Health Fittings for Improved Safety and Suicide Risk Reduction

In 2007, the *Joint Commission* established suicide prevention as a National Patient Safety goal. Their Technical Expert Panel recommended that psychiatric hospitals and inpatient psychiatric units in general medical/surgical hospitals should be made "ligature-resistant" to decrease the risk of suicide by hanging.

Source: Journal on Quality and Patient Safety 2018, The Joint Commission

SLR Shower Solutions for Behavioral Health

SLR Series **Ligature Resistant*** Showers



Ligature Resistant Shower Trim*

Works with the 1920 Series valve (1920-VONF)

- + Rounded, sloped design minimizes ligature points
- + Tamper resistant screws
- + Solid brass construction to withstand abuse



Ligature Resistant Shower Head*

- + Sloped, low profile design with no shower arm
- + Anchored to wall with four tamper resistant screws
- + Adjustable spray angle of 25° – 30°



1920 Series **High-Performance Shower Valve**

- + Certified to ASSE 1070 to help prevent scalding
- + Protects users against scalding by compensating for changes in both the water temperature and pressure
- + Advanced thermal actuator technology, maintains a consistent temperature

***DISCLAIMER** This product, when installed in accordance with the Installation Instructions, is designed to decrease the probability that it may be utilized as an apparatus for ligature. Chicago Faucets does not represent or warrant that this product is able to prevent death or injury, or resist all ligature attachment, and this product is not a substitute for the proper evaluation, treatment and supervision of persons at risk of suicide. Chicago Faucets makes no express or implied warranties regarding the ability of the product to prevent death or injury or resist all ligature attachment.

Incidence of Inpatient Suicides

As many as

65

inpatient suicides occur each year in the United States.

Almost

75%

of all inpatient suicides occurred during psychiatric treatment.

Over

70%

of all inpatient suicides were reported to be the result of hanging.

Safety and Laboratory Fittings

Unparalleled Quality

Innovations for Safer Laboratories

At Chicago Faucets, we bring superior quality, design, and support to laboratory environments with our extensive range of safety and laboratory products. From safety fittings to laboratory pure water fittings, our solutions are engineered to meet the highest standards of safety, performance, and flexibility.

Our offering includes:

- + **Eyewashes:** Compliant with ANSI Z358.1 and available to suit a facility's safety requirements.
- + **Valves and Turrets:** Ball and needle valves for air, gas, and vacuum services, as well as turrets with multiple outlets and single or dual inlets.
- + **Water Laboratory Fittings, Air, Gas, and Vacuum Laboratory Fittings, and Pure Water Laboratory Fittings.**



Designed with modularity in mind, our laboratory product components are interchangeable, allowing you to customize solutions that fit your unique needs. With Chicago Faucets, you have a single source for all your water delivery needs—from the lab to restrooms, janitorial spaces, cafeterias, and beyond.

We offer a full selection of laboratory safety fittings precisely manufactured for safety and certified for use in hospital laboratories. Lab and safety managers can choose from a range of safety showers, eyewashes, and combination faucet/eyewash units to meet their specific layouts and safety requirements.

Our safety fittings are designed to help hospitals create a safer environment for staff and patients in the event of chemical exposure or other emergencies. Compliance with standards like ANSI Z358.1 ensures our emergency equipment meets rigorous safety requirements. Additional certifications include ASME A112.18.1/CSA B125.1, NSF/ANSI/CAN 372, NSF/ANSI/CAN 61, and ASSE 1071.

For more details, refer to the [Chicago Faucets Definitive Guide to Codes & Standards for Eyewash Systems](#).

Safety and Emergency Products

Emergency Eyewashes and Safety Showers

Chicago Faucets emergency and safety fittings comply with industry standards, use high-visibility materials, and offer a variety of fixture types and activation methods, helping hospitals create a safer environment for their staff and patients in the event of a chemical exposure or other emergency.

8450 Series Emergency Eyewash and Faucet Combinations

This compact series is available in both manual and electronic activation models, each including a single-action handle operation to offer facilities a safe, quick, and easy-to-use option while eyes are compromised. Designed with an independent supply line for eyewash, the 8450 Series provides contamination prevention and temperature control with an optional thermostatic mixing valve to ensure the eyewash is ready for use at all times.

Electronic Faucets		Manual Faucets	
			
Touchless	Lab Nozzle Eye Wash	Single Handle Sidemix	Manual, 4" Wristblade Handles

Safety Showers

The safety shower fittings feature an anti-corrosive polyamide 11 yellow plastic coating to enhance the durability, accessibility, and safety compliance of laboratory plumbing fittings for emergency equipment. Both showers with eyewashes and safety showers are easy to locate in an emergency, improving accessibility and response time.

Safety Showers	Eyewashes with Safety Showers		
			
Emergency Drench Shower Fitting	Emergency Face Wash, Drench Shower Fitting	Emergency Eye/Face Wash Fitting	Emergency Eye/Face Wash, Drench Shower Fitting

Safety and Laboratory Fittings

Reliability for Laboratories

Water Laboratory Fittings

Water laboratory fittings are necessary to meet the unique requirements of a laboratory setting, where precise control, safety, and reliability are paramount. The flexibility, versatility, and safety features of the Chicago Faucets water fittings help labs create a functional and secure plumbing system that supports their critical operations.

- + **Mounting Flexibility:** The ability to mount the fittings on decks, walls, or panels provides flexibility in lab layout and equipment placement.
- + **Versatile Applications:** The fittings can accommodate single water, dual water, and multi-service applications, allowing labs to tailor the plumbing to their specific needs.
- + **Vandal Resistance:** The vandal-resistant features help ensure the integrity and safety of the fittings in a high-traffic laboratory environment.
- + **Ease of Use:** The handles with service buttons make the fittings easy to identify and operate, improving usability for lab personnel.
- + **Backflow Prevention:** The backflow prevention features help maintain water quality and safety by preventing contaminants from entering the water supply.



Single Supply



Dual Supply, Single Hole

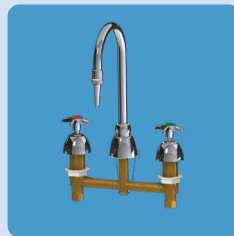

Dual Supply, 8" Centers



Triple Service Fitting

Precision and Control

Air, Gas, and Vacuum Laboratory Fittings

Air, Gas, and Vacuum fittings are an essential part of a modern laboratory's utility service distribution system, enabling controlled and safe access to the air, gas, and vacuum sources required for a wide range of scientific work. Chicago Faucets offers a variety of options in different mounting configurations, including precise control valves, turret-mounted valves, and remote valves with epoxy coatings in a variety of colors.

- + **Deck, Wall, and Panel Mounted Products:** The ability to mount the fittings on decks, walls, or panels is important to provide flexibility in lab layout and equipment placement.
- + **Ball and Needle Valves for Air, Gas, and Vacuum Services:** These valve types offer precise flow control of air, laboratory gases, and vacuum service, with maximum durability for demanding lab environments.
- + **Turrets with Multiple Outlets and Single and Dual Inlets:** Turrets with multiple outlets and single/dual inlets allow for the distribution of air, gas, and vacuum services to multiple points of use from a single fitting. They optimize space and streamline the plumbing layout in the lab.
- + **Remote Valves for Fume Hoods:** Remote valves for fume hoods enable the control of air, gas, and vacuum services directly from the fume hood, improving safety and accessibility.
- + **Epoxy Coatings:** Epoxy coatings in a variety of colors help visually distinguish different supply services to prevent misconnections and improve safety.



Remote Panel Valve

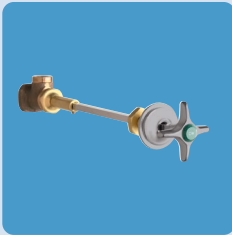

Remote Panel Valve



Remote Deck Valve



Remote Spout

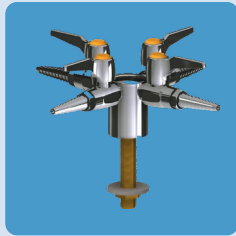

Single Service Turret



Single Service Wall Valve



Dual Service

Safety and Laboratory Fittings

Corrosion-Resistant and Adaptable

Pure Water Laboratory Fittings

Chicago Faucets pure water laboratory fittings are quality crafted for corrosion resistance, chemical compatibility, purity maintenance, temperature and pressure resistance, flexibility, and adaptability. They are made of assorted materials for Distilled, Deionized, and RO applications and reagent water types I, II, and III.

- + **Manufactured with Corrosion Resistant Materials:** Tygon®, Polyvinyl Chloride (PVC), polypropylene (PP), and fluoropolymers like Polyvinylidene Fluoride (PVDF) with circulating features are highly resistant to corrosion, making them suitable for conveying deionized and ultra-pure water.
- + **Chemical Compatibility:** Thermoplastics like Tygon®, PP, and PVDF are chemically inert and do not leach contaminants into the pure water. The specialized linings in the chrome fittings also help maintain water purity.
- + **Purity Maintenance:** Materials like PP and PVDF can be manufactured without additives, plasticizers, or pigments that could contaminate the pure water. The socket-fused PP piping and fittings create a durable, leak-proof system to preserve water purity.
- + **Flexibility and Adaptability:** The variety of materials offered, including thermoplastics and chrome-tin lined fittings, allows laboratories to select the most appropriate solution for their specific pure water requirements.
- + **Temperature and Pressure Resistance:** High-performance materials can withstand the high temperatures and pressures often found in laboratory pure water systems.



Polyvinylchloride



Polypropylene

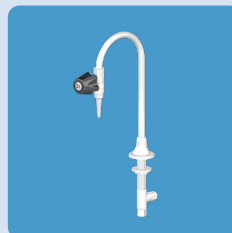

PVDF Recirculating

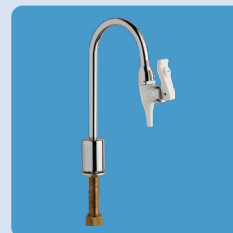

Tygon® Lined

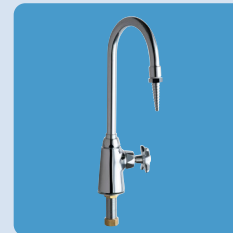

Tin Lined

Dependable for Heavy Use

Durable Manual Faucets

With the most dependable food service fittings in the industry, we're the one company you can count on for every sink in your building. Whether you need pot fillers at the stove, pre-rinse or washdown fittings for dish prep, dipper well and glass fillers in the bar area, handwashing faucets... you name it: Chicago Faucets makes the plumbing fittings you need to keep your cafeteria or commercial kitchen operating at peak efficiency.

Glass and Pot Fillers



Glass Filler



Flexible Pot Filler



Pre-Rinse



Standard Pot Filler

Pre-Rinses and Valves

Chicago Faucets offers deck and wall mounted customizable pre-rinse units for standard and short heights that include our 90 Series Pre-Rinse valves, the most sustainable in the industry. It is a durable and dependable long-life fitting for every kitchen.

The 90 Series Pre-Rinse Valve

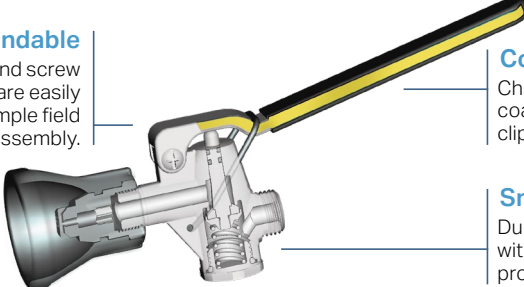

Dependable
Stainless steel post and screw feature Philips heads, are easily accessible, and allow for simple field replacement of handle assembly.

Convenient
Chrome plated brass handle with PVC coating and integrated hold-down clip for durability and convenience.

Heavy Duty
Heavy duty, tool-free, field replaceable bumper sides over nozzle and locks into place.

Smooth Activation
Durable solid brass valve body with nickel plated brass valve stem provides smooth valve activation.

Performance
Field replaceable one piece stainless steel nozzle with 1.0 gpm @ 60 PSI performance.

Ease of Use
3/4" - 14 UNS male thread allows standard attachment.

Maintenance Products

Chicago Tough For the Toughest Jobs

Janitorial and Maintenance Plumbing Fittings

Faucets in janitorial and maintenance sink locations are subjected to more abuse than any other faucet in your facility. Their exposure to chemicals and other contaminants can also create a significant backflow hazard to the potable water in your building. Choosing the right faucets for service sink locations is extremely important – there isn't a better choice than Chicago Faucets. Our service sink faucets are engineered for high-use, high-abuse commercial applications and feature:

- + Heavy-duty, solid cast brass construction for unsurpassed durability
- + A choice of atmospheric and continuous pressure spill resistant vacuum breaker spouts to cover all service sink applications
- + Vacuum breakers integrated into the spout to help reduce backflow risk
- + Top-mounted wall bracket that provides extra stability and doesn't interfere with filling floor-standing buckets
- + Repairable Quatern™ operating cartridges for dependable operation and easy maintenance
- + Integrated pail hook and hose threaded outlet for added convenience

Vacuum Breaker Spouts Help Reduce the Risk of Backflow

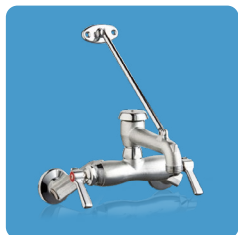

Service Sink

Atmospheric Vacuum Breaker Spout

Our atmospheric vacuum breaker spout is designed for use on non-pressurized systems. When installed properly, it can provide excellent protection against backflow. The spout incorporates a vacuum breaker that is closed by the ambient air pressure when the water flow is off. It helps prevent backflow from a non-pressurized source – like a hose submerged in a bucket of contaminated water.



Service Sink High Hazard

Spill Resistant Vacuum Breaker Spout

Our spill resistant vacuum breaker spout is designed for use on continuous pressure lines and is recommended for any application with system connections or shut-offs downstream. The spout incorporates a vacuum breaker with a spring-loaded poppet that helps prevent contaminated water from entering the water supply. The vacuum breaker must be installed vertically. Pressure must not exceed 150 psi.



Chicago Faucets +Healthcare

Chicago Faucets creates products that enhance the quality of care in healthcare facilities. We provide architects, designers, specifying engineers, and facility managers with high-quality products tailored to the specific needs of healthcare professionals and their patients.

Our focus on safety can be seen across our entire suite of faucets and showers. Our products are 100% compliant and designed for infection prevention, scald prevention, or ligature protection. With a reputation for proven performance and reliability, Chicago Faucets +Healthcare ensures worry-free specification, exceeding the most demanding expectations.

Healthcare water systems face challenges like complex distribution pathways, stagnant areas, exposure to different materials, and variations in temperature, pH, and disinfectants. These conditions can lead to the growth of pathogens. Patients and residents undergoing rehabilitation may be at risk of infection or exposure to outbreaks. Choosing the +Healthcare line of plumbing fittings enhances patient and staff safety.

Get started with Chicago Faucets, visit <https://info.chicagofaucets.com/plushealthcare>

Let's meet about your project: <https://info.chicagofaucets.com/lets-meet>



2100 South Clearwater Drive, Des Plaines, IL 60018

Phone: (847) 803-5000 Fax: (847) 832-1845 Technical: (800) 832-8783

www.chicagofaucets.com

